

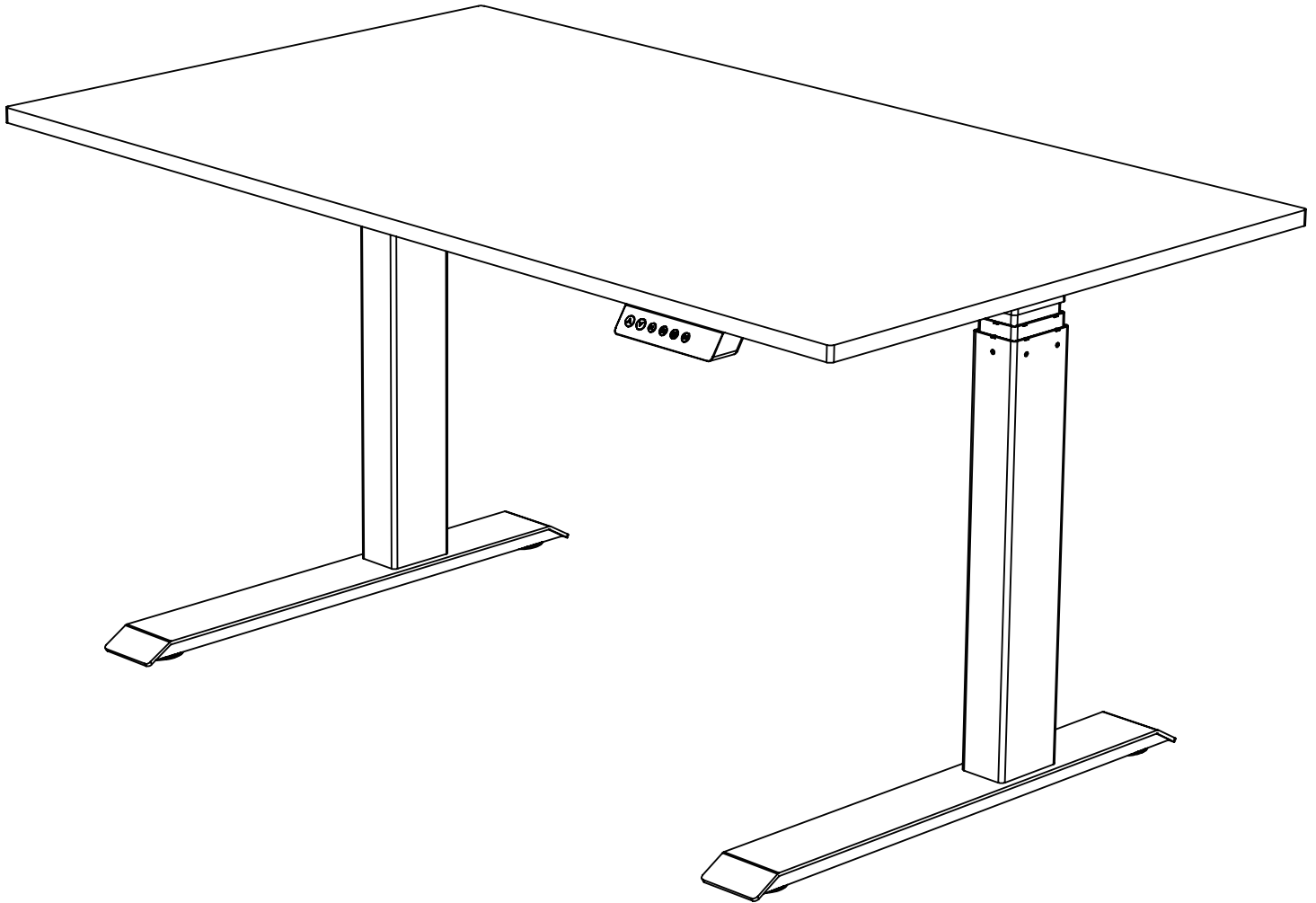

A better way to work



Height range: 25.6 x 51.2 in / 650-1300 mm

Weight capacity: 155 lbs / 70 kg

Features: Single electric motor, three-stage legs, programmable keypad with four memory settings

Notes: Desktop packaged separately, images may vary from purchased desk

Questions or concerns? Contact us directly!

1-855-843-7920

CustomerService@StandUpDeskStore.com



Electric Motor / Programmable / 3-Stage Legs

PARTS INCLUDED NOT TO SCALE

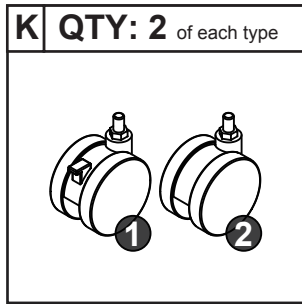
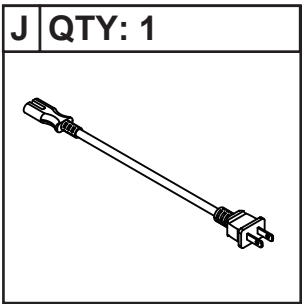
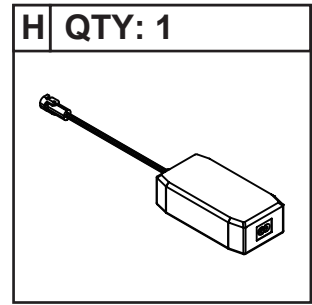
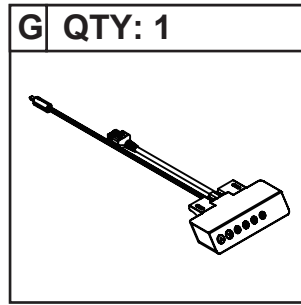
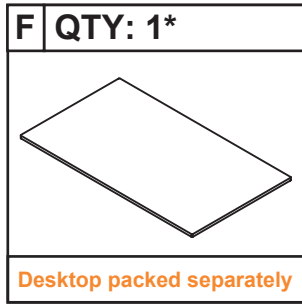
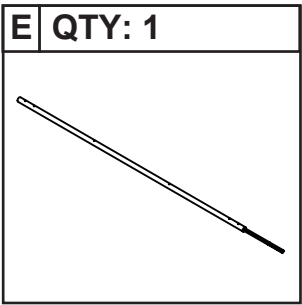
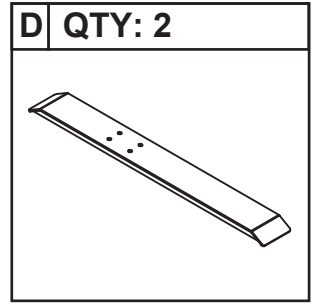
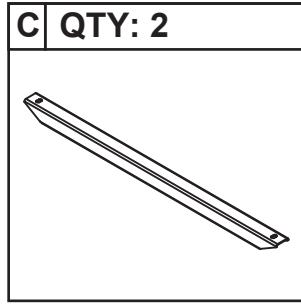
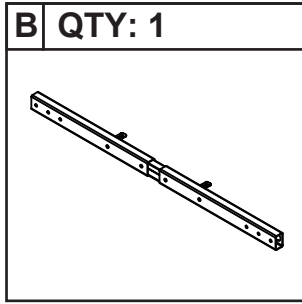
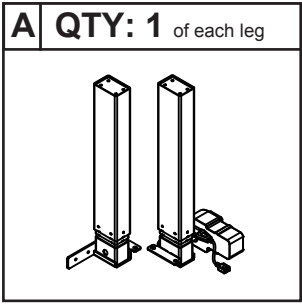

HARDWARE INCLUDED NOT TO SCALE

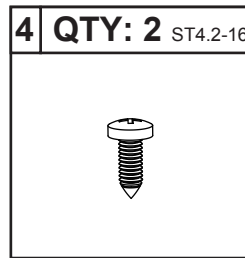
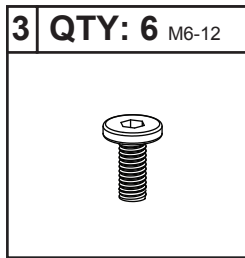
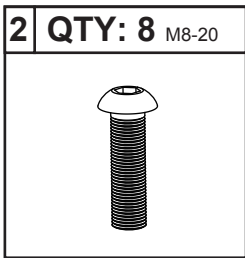
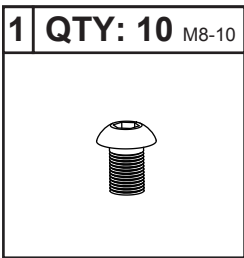

TOOLS INCLUDED

TOOLS REQUIRED

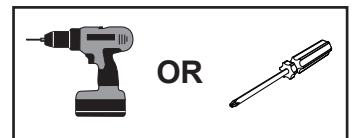
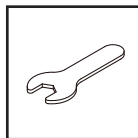
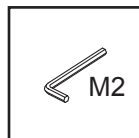
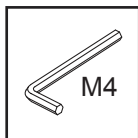
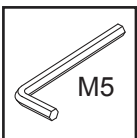

ASSEMBLY

1

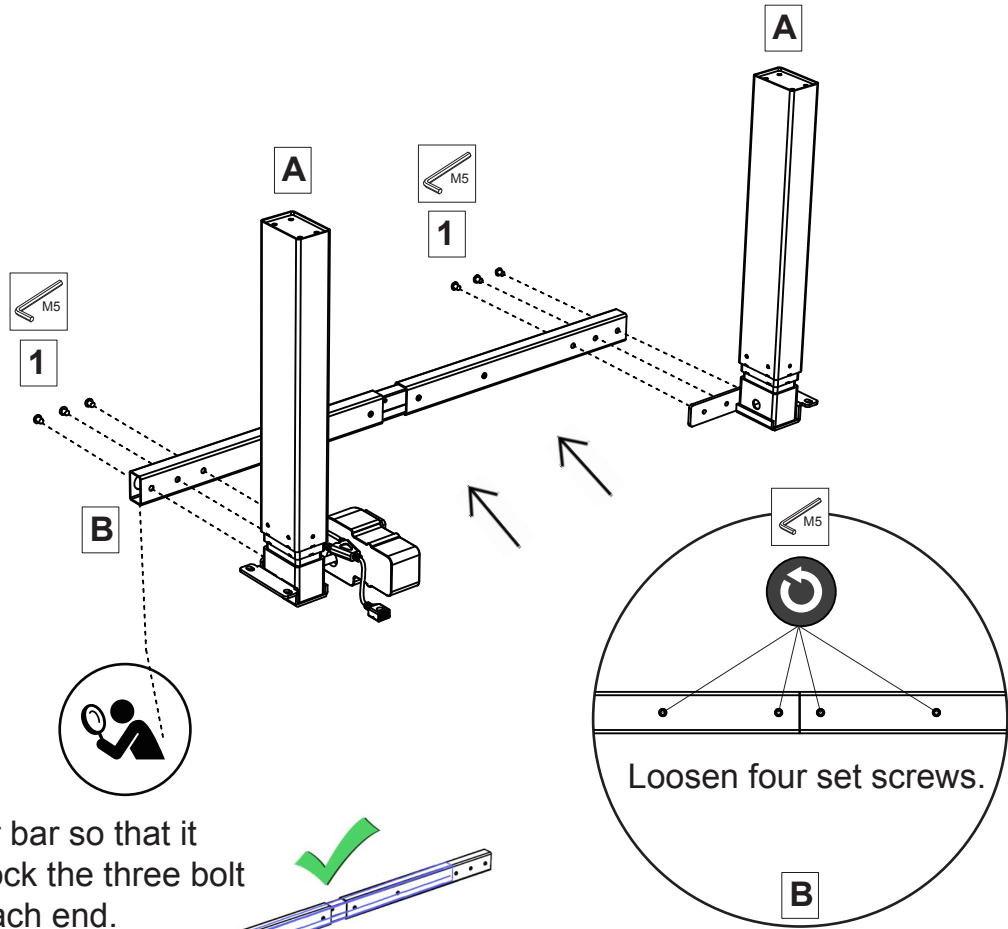

Align inner bar so that it doesn't block the three bolt holes at each end.

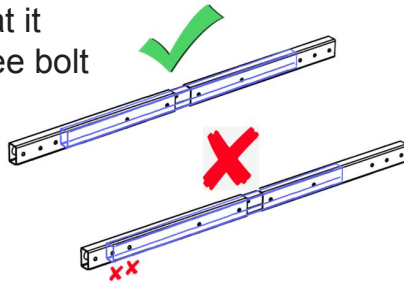

2

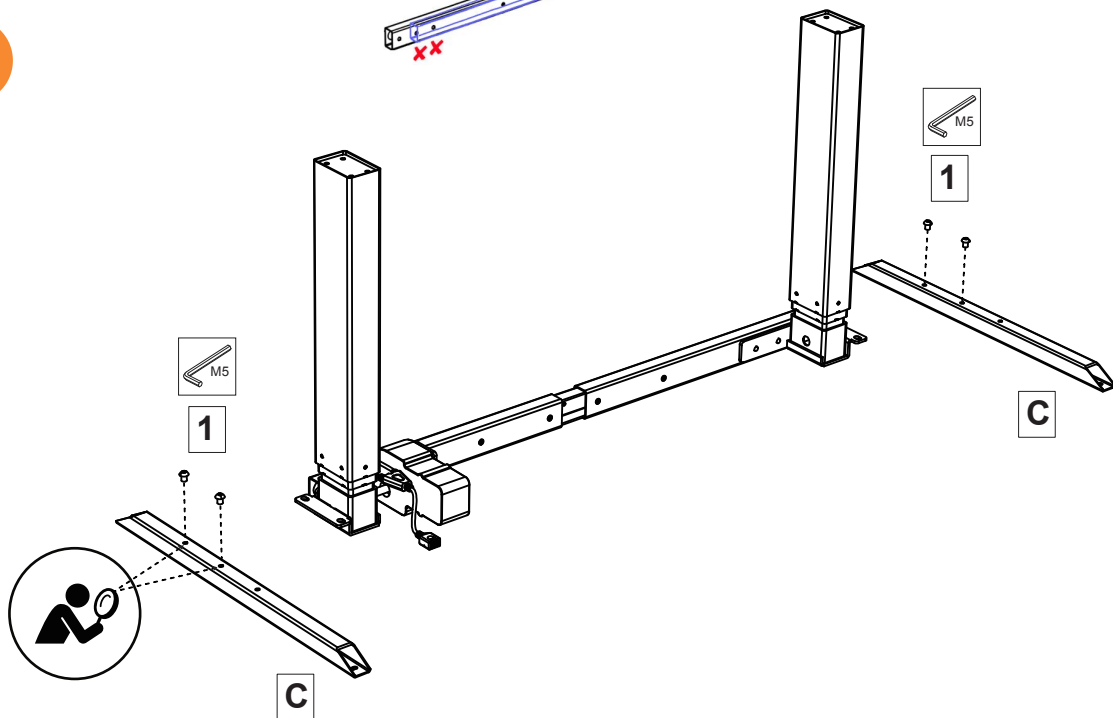

3

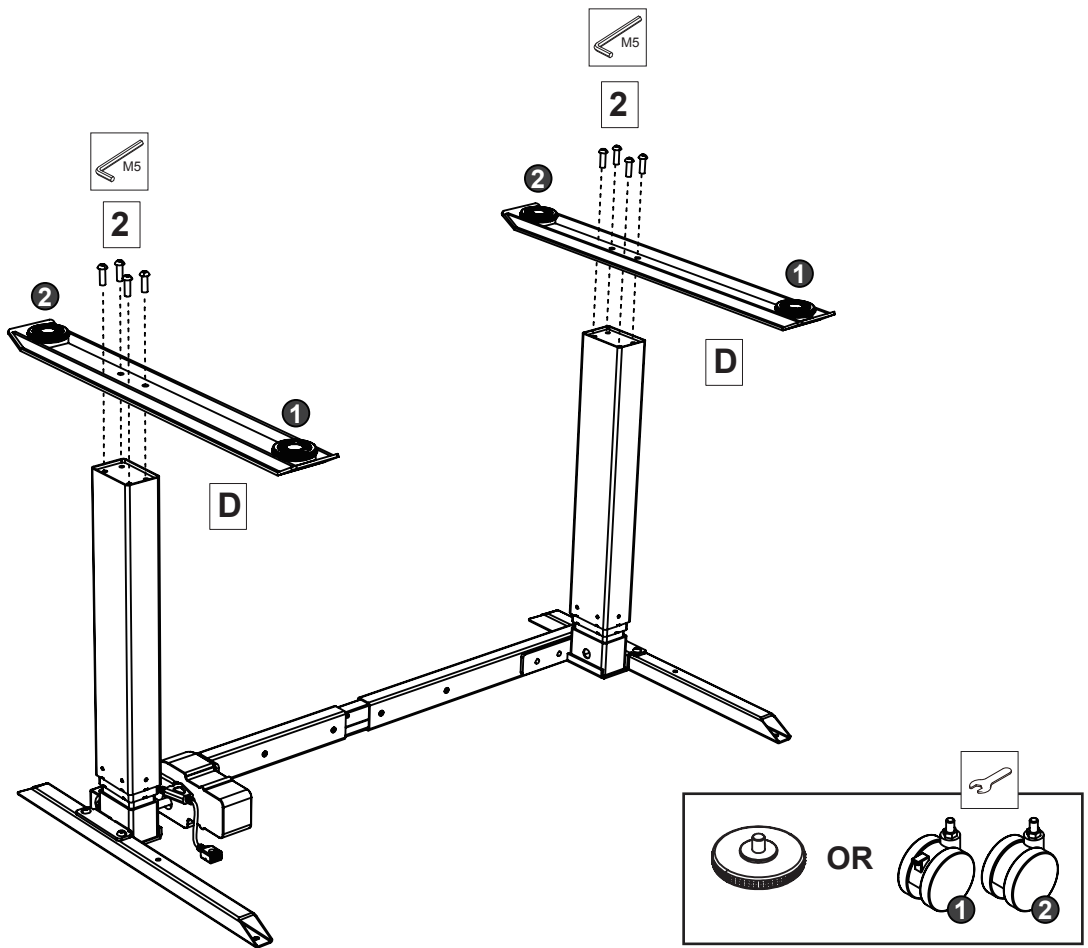

4

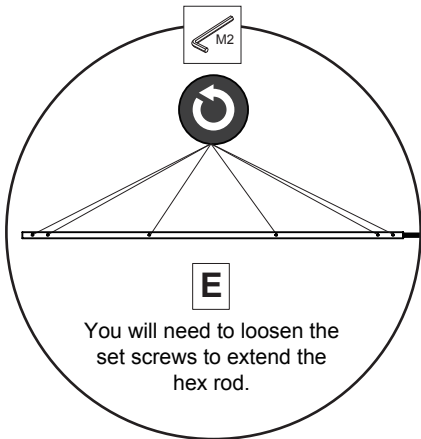

You will need to loosen the set screws to extend the hex rod.

- 48" AND 60" DESK:**
1. Expand frame.
 2. Loosen hex rod set screws.
 3. Insert hex rod.
 4. Extend hex rod.
 5. Tighten hex rod set screws.
 6. Push together frame.

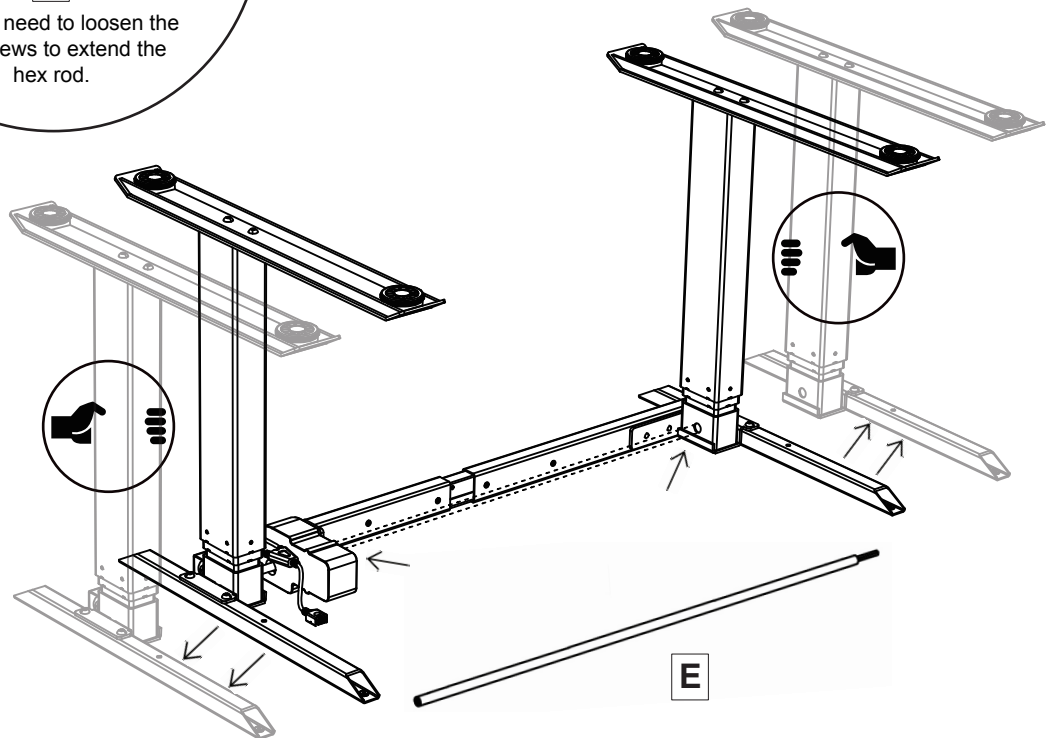

5

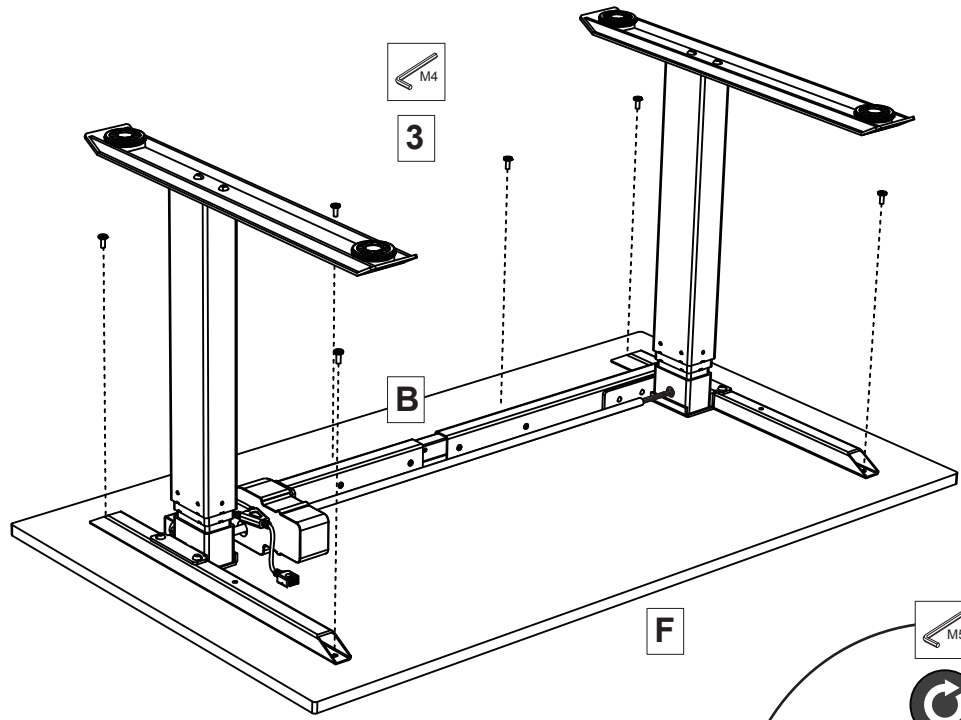

IF HEX ROD WON'T INSERT:

If the hex rod won't insert into the frame, this means the legs are misaligned. If you cannot insert the hex rod:

1. Skip to the next desk assembly step.
2. Follow instructions to complete the desk assembly.
3. Refer to the Leg Misalignment Instructions in the Troubleshooting section.

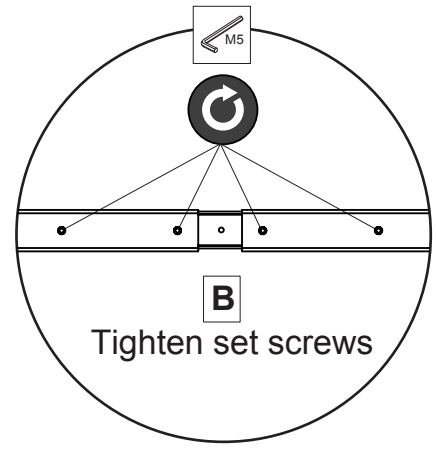

6

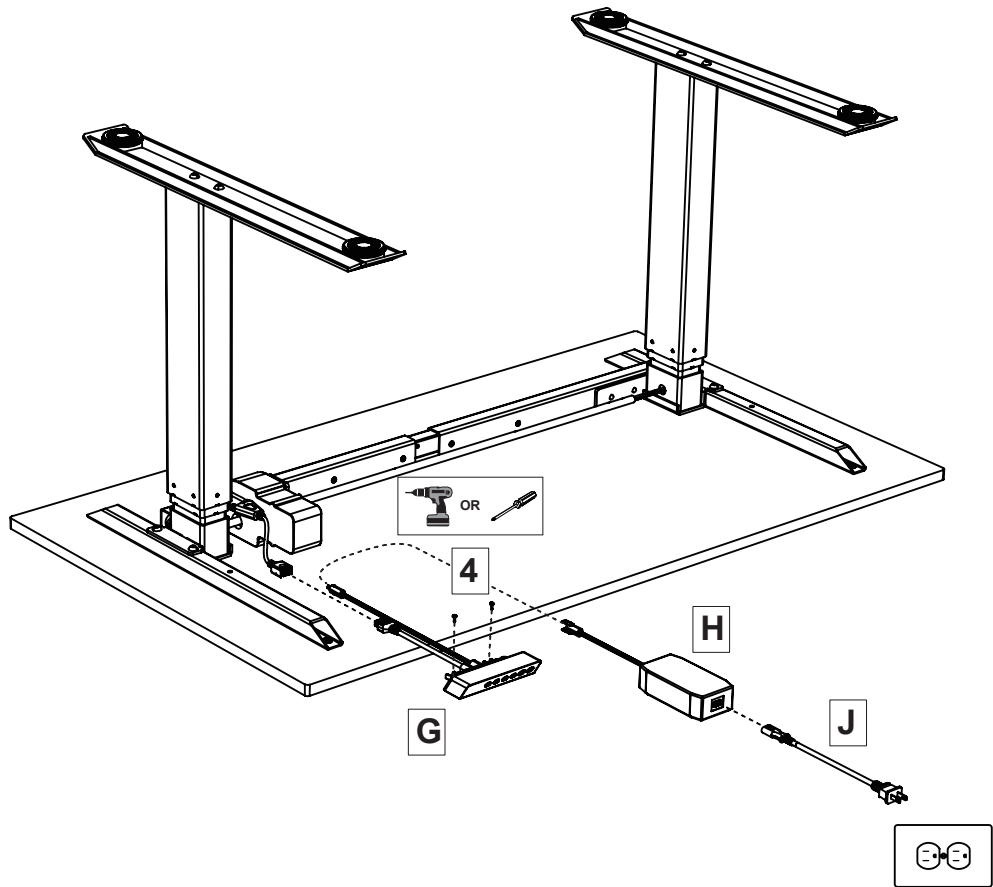

7

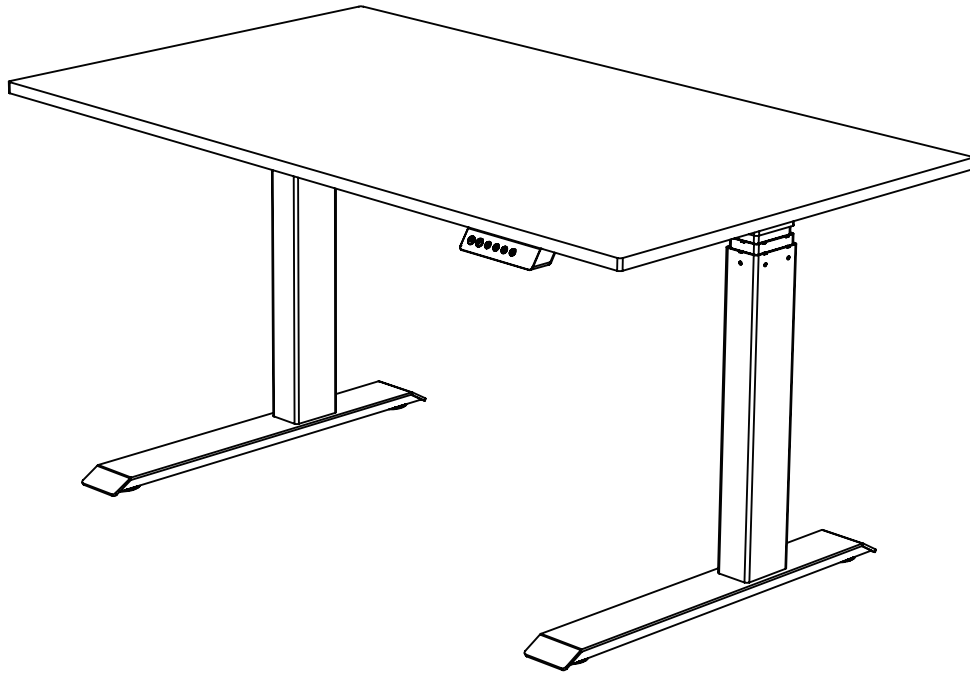

ASSEMBLY HELP

Prefer video instructions? View our video page!

1-855-843-7920
CustomerService@StandUpDeskStore.com



HEIGHT ADJUSTMENT & PROGRAMMING

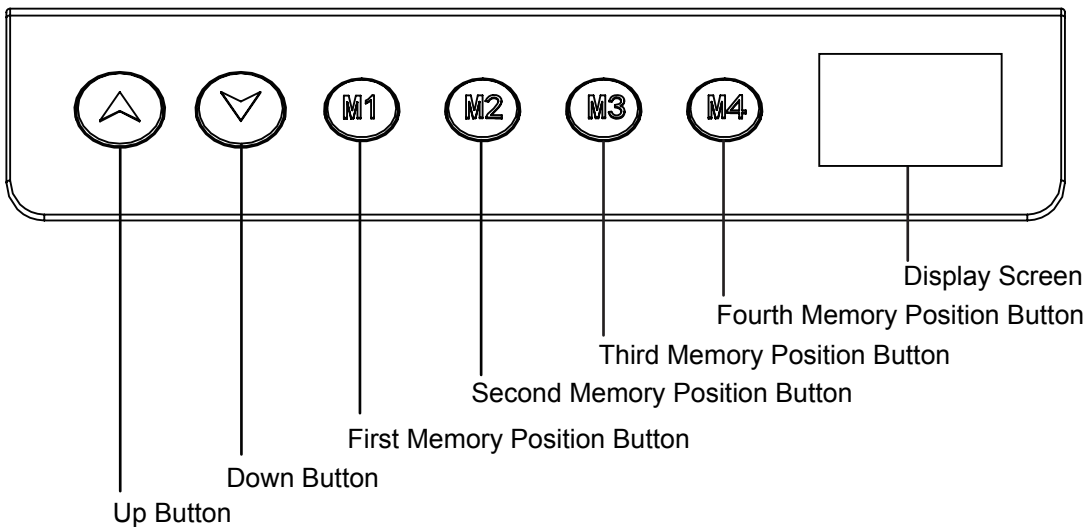

PROGRAMMING INSTRUCTIONS:

1. Push and hold Up or Down key until desk reaches desired height.
2. Choose M1, M2, M3, or M4 as your memory position.
3. Press and hold that button until you hear one beep (approx. 5 seconds).
4. To recall a saved memory position, press the corresponding button.

TROUBLESHOOTING

See an error code on your standing desk, and not sure what to do? Use this guide to quickly identify and fix the issue.

Error Code	Problem	Solution
ER1	Motor issue	Complete a Hard Reset .
ER2	Synchronization issue	Complete a Hard Reset .
ER3	Cable issue	Complete a Hard Reset .
ER4	Communication issue	Complete a Hard Reset .
ER5	Weight limit exceeded (desktop load is more than 397 lbs./180 kg)	Complete a Standard Reset . If the desk still does not function properly, complete a Hard Reset .
HOT	Continuous use beyond 2 minutes	Complete a Standard Reset . If the desk still does not function properly, complete a Hard Reset .
ASR	Motor issue	Complete a Hard Reset .

Standard Reset Instructions: Press and hold the down button until the desk is at its lowest height. Unplug the power cord for ten minutes. After ten minutes, plug the power cord back in. This should reset the unit and remove the error code. If the problem persists, try a Hard Reset.

Hard Reset Instructions: Press and hold the down button until the desk is at its lowest height. Unplug all cables attached to the desk, including connection cables, keypad, and power cord. Press the down button for 10 seconds, then allow the desk to sit for 10 minutes. After 10 minutes, plug all connection cables back in, ensuring they are attached properly. The desk should now function properly. If the desk will not lower on step one, once the connections cables are attached after the 10-minute reset, press the down button to bring the desk to its lowest height. Then complete the hard reset once more.

Leg Misalignment Instructions

If the height of the legs are misaligned, you will not be able to insert the hex rod because the hex rod receptacles at the top of each leg are not lined up. To fix this:

1. Plug in the desk.
2. Press the Down button until the right side leg bottoms out.
3. If the hex rod receptacles line up, insert the hex rod into both sides (on 60" models, then tighten the set screws).
4. If the hex rod still doesn't line up, press the Up button in very small increments until the hex rod receptacles line up.
5. When the hex rod receptacles line up, insert the hex rod into both sides (on 60" models, then tighten the set screws).

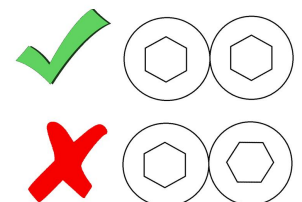

SETTINGS

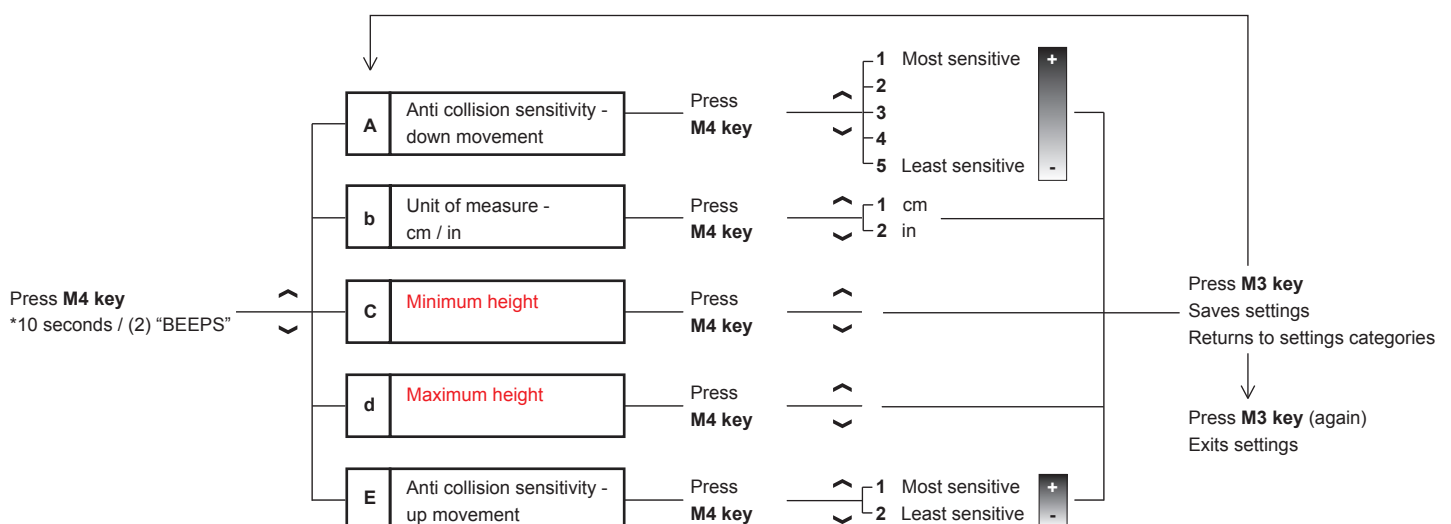

CAUTION

- Keep children away from desk - especially the keypad, motor, power brick, legs, or cables - to avoid risk of electric shock or serious injury.
- Do not open any components - especially the keypad, motor, power brick, legs, or cables - to avoid risk of electric shock or serious injury.
- Close supervision is necessary when children, elderly, or persons with disabilities are in close proximity.
- Keep all electrical components away from liquids and areas where exposure to liquids can occur.
- Do not sit or stand on desk. Do not crawl or lie under desk.
- Do not place any object taller than 20" (when using glides) or 23" (when using casters) under desk.
- Never operate desk if cords, plug, keypad, and other electrical components are wet or damaged.
- Make sure there are no obstructions above or below the desk which could impede its ability to raise and/or lower.
- Make sure all power cords are of appropriate length to accommodate desk's full range of motion.
- Never exceed the desk's weight capacity.
- Ensure all hardware are properly tightened.
- If a component needs to be replaced, unplug power cord before uninstalling or reinstalling it.
- In the event of a power outage or accidental removal of power cord, a manual reset may be necessary. See **MANUAL RESET**.

USE & LIABILITY

Read all instructions before using desk. Keep instructions for reference. Manufacturer does not accept warranty claims or liability claims for damages caused by improper use or handling.

PRODUCT HELP

Need assistance with programming or troubleshooting? View our video page!

1-855-843-7920
CustomerService@StandUpDeskStore.com

